

NOTES

- 1 M08 EQUALIZER PACKAGE
- 2 MATERIAL: 6061-T6 HOUSING, STAINLESS CONNECTORS
- 3 FINISH: ELECTROLESS NICKEL PLATE
- 4 M/M, F/F SMA CONFIGURATIONS AVAILABLE ON REQUEST

REVISION HISTORY				
REV	ZONE	DESCRIPTION	APPROVED	DATE
-		INITIAL RELEASE	JJM	22/03/25

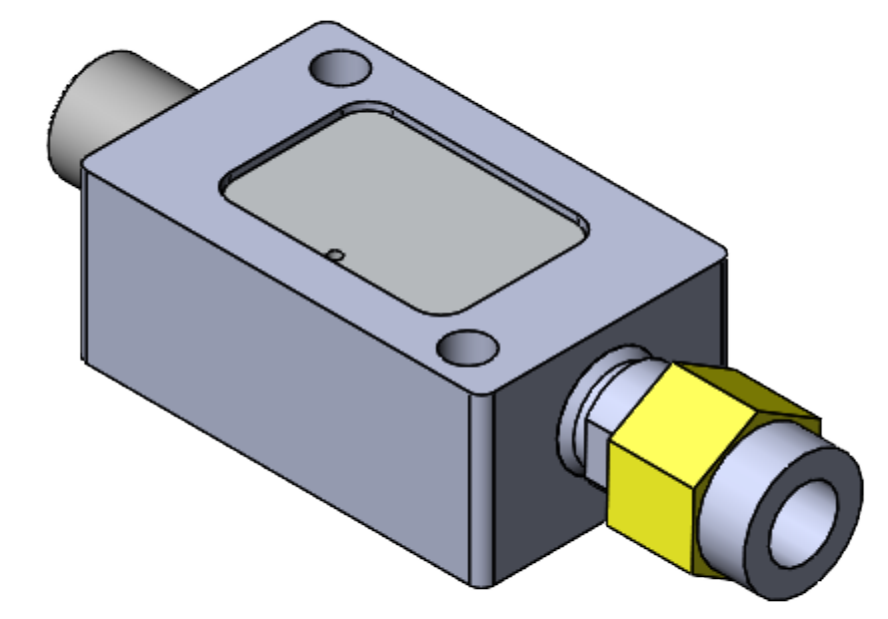
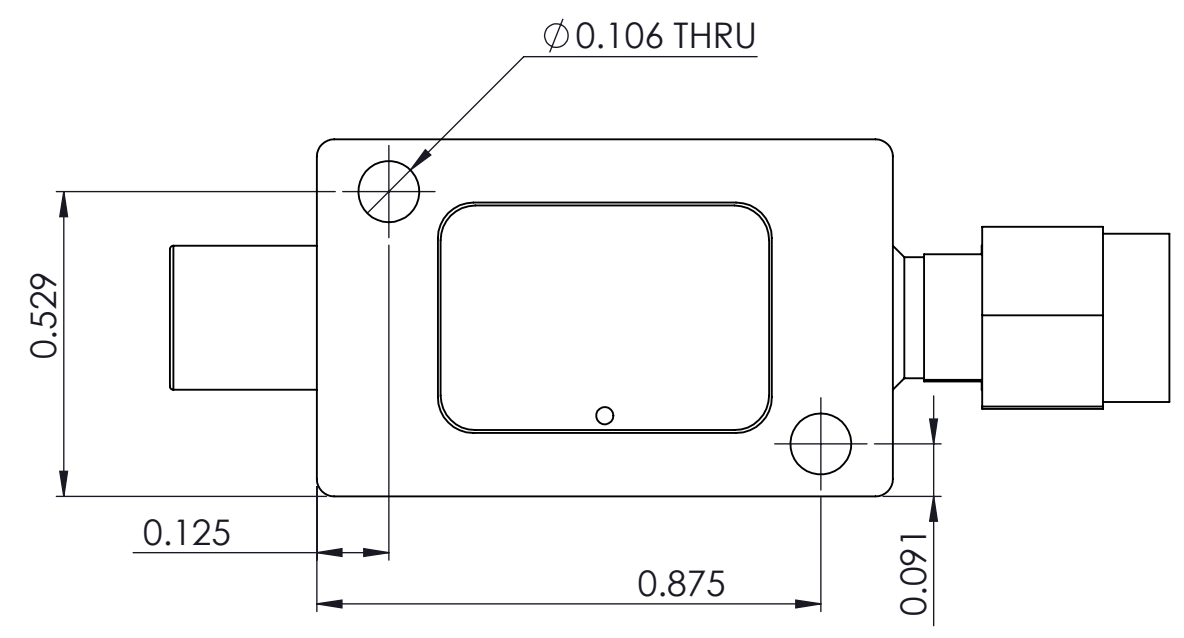

ISOMETRIC VIEW FOR REFERENCE ONLY
SCALE 3:1

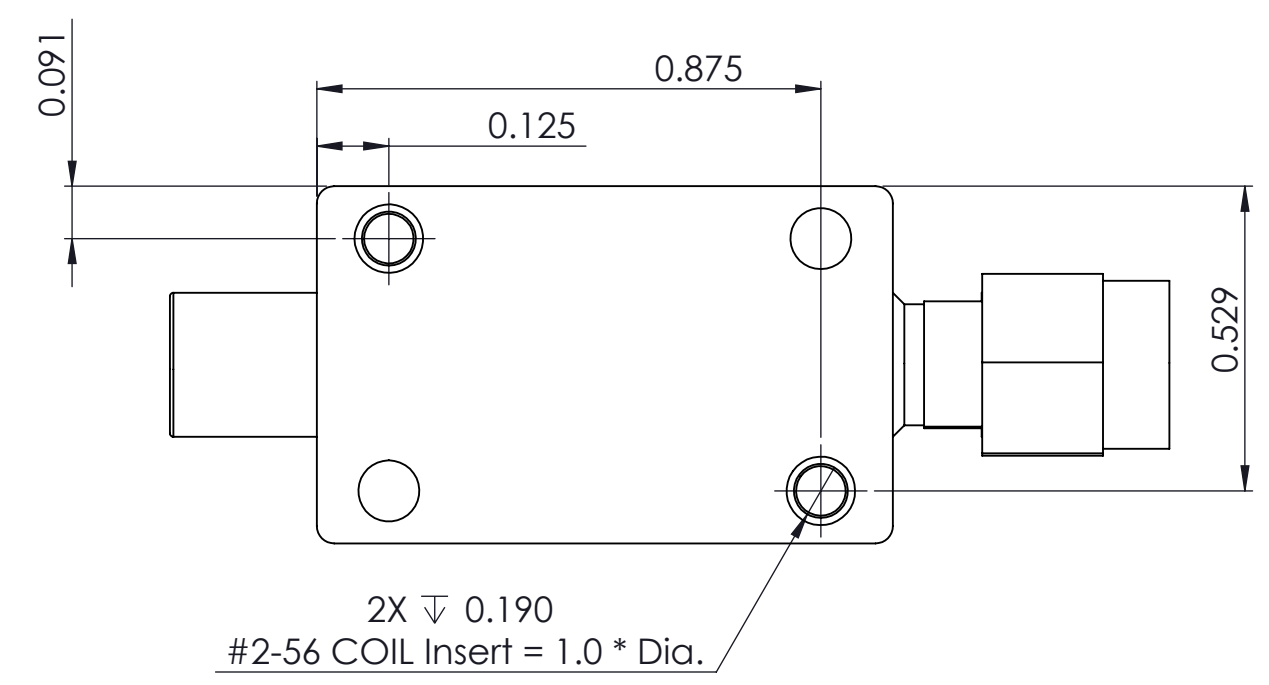
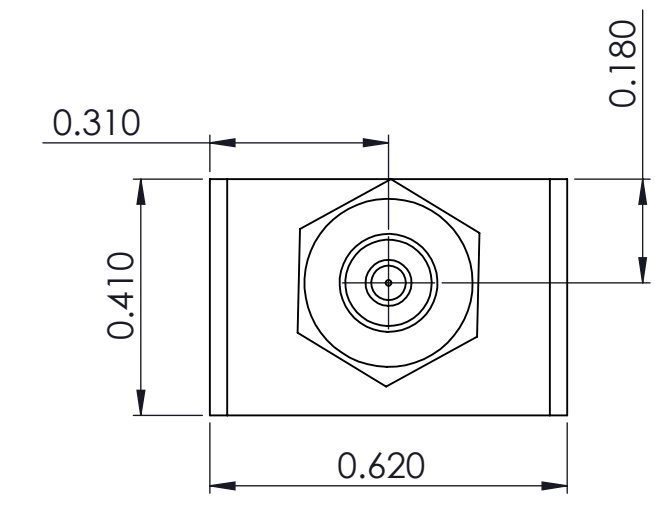
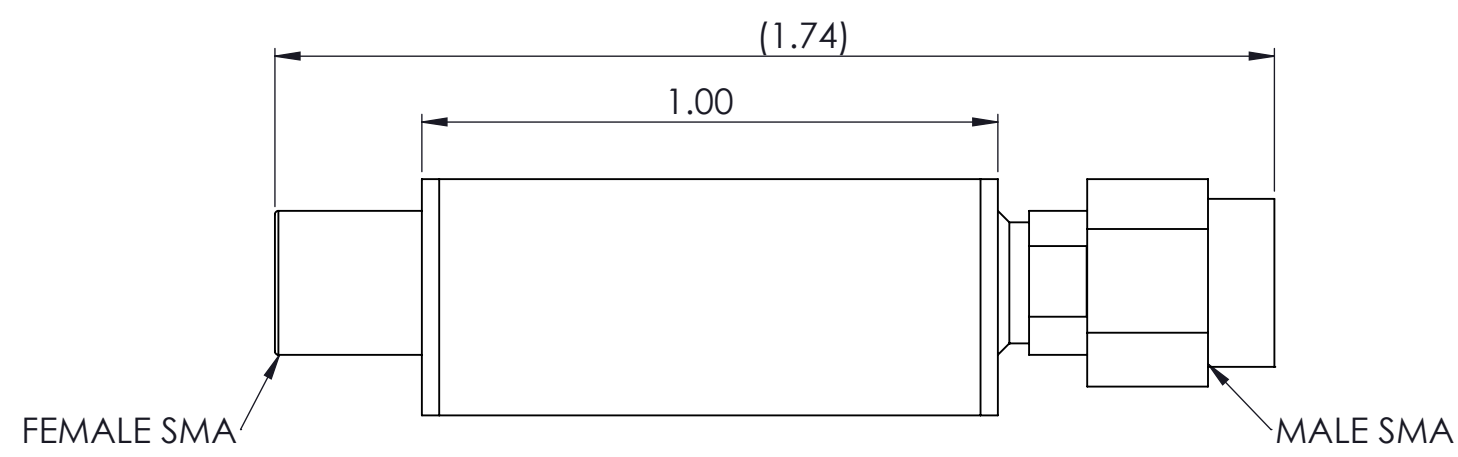
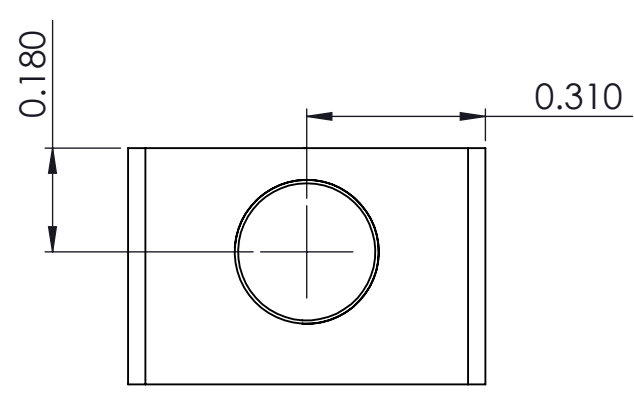

PROPRIETARY AND CONFIDENTIAL
THE INFORMATION CONTAINED IN THIS DRAWING IS THE SOLE PROPERTY OF R.A. WOOD ASSOCIATES. ANY REPRODUCTION IN PART OR AS A WHOLE WITHOUT THE WRITTEN PERMISSION OF R.A. WOOD ASSOCIATES IS PROHIBITED.

UNLESS OTHERWISE SPECIFIED:		NAME	DATE
DIMENSIONS ARE IN INCHES		DRAWN	JJM 22/01/28
TOLERANCES:		CHECKED	DS 22/03/25
FRACTIONAL ±		ENG APPR.	
ANGULAR: MACH ± 1°		MFG APPR.	
TWO PLACE DECIMAL ±.02		Q.A.	
THREE PLACE DECIMAL ±.005		COMMENTS:	
INTERPRET GEOMETRIC TOLERANCING PER ASME Y14.5			
MATERIAL			
FINISH			
NEXT ASSY	USED ON		
APPLICATION			
DO NOT SCALE DRAWING			



EQ, M08

SIZE	CAGE CODE	DWG. NO.	REV
C	39MZ0	M08_ICD	-
SCALE: 3:1		SHEET 1 OF 1	